

COMPACT SAW MOTORS



Use	Compact saw motors are studied for all those applications in which an high output but limited dimensions are required. They are particularly suitable for applications on cutting machines (e.g. circular saws) where their lowered shape allows the maximum exploitation of the cutting height. These motors should work in intermittent S3 or S6 service for letting the motor be cooled enough.
Shaft	These motors are supplied with threaded shaft (right or left) in the standard execution, nut and flanges but. Shafts can also be modified according to our customer specifications and supplied with a front flange and shaft design . Balancing with half key.
Housing	Light alloy flat extruded. With small flaps on lateral and bottom side for heat dissipation and for motor mounting via mounting rails and inserts T.
Terminal box	Plastic or aluminum. It is usually located on the right side of the engine, near the exit shaft. On request It can also be placed on the left side or top of the engine, near the exit of the shaft or near the fan cover. It can also be rotated of 90 ° to allow the cable entry to be positioned where needed.
Cooling	Compact motors are equipped with bi-directional radial fan that provides excellent ventilation of the engine. Forced cooling supplied upon request.
Fan cover	Built in thermoplastic material up to size 90, in aluminum for motors size 100.
Rotor	Cage rotor, die cast aluminum alloy
Protection	IP54 standard, on request IP55 .
Winding	With double winding copper wire enamel, insulation class F or H.
Available types	Type SE: Three phase motors from frame H48 up to frame H100. Type SEF: Three phase motors with dc security brake, from motor frame H71 up to H100. Type SEP: Three phase motors with pneumatic brake, available only for frame H80 and H100 The overall dimensions of the compact motors with brake do not vary from those without brake. They are the same.

Type	kW	Hp	rpm 50Hz	rpm 60Hz	η %	Cos	In* 230V 50Hz	In* 400V 50Hz	Weight kg
3000 RPM – 2 POLES- TYPE SE									
H48S2se	1.3	1.8	2700	3400	80	0.80	5	2.9	10
H48L2se	1.7	2.3	2700	3400	80	0.80	7.2	4.1	12
H71a2se	1.5	2	2860	3430	80	0.80	6.7	3.9	16.5
H71c2se	2.2	3	2875	3450	80	0.80	9.6	5.5	20
H80Sb2se	3	4	2890	3470	85	0.84	12.5	7.2	24
H80m2se	4	5.5	2890	3470	85	0.84	16	9.3	28
H80L2se	5.5	7.5	2890	3470	85	0.80	21.6	12.5	35
H90S2se	5.5	7.5	2880	3450	86	0.85	19.1	11	40
H90L2se	7.5	10	2885	3460	86	0.86	26.5	15.3	46
H100S2se	9.2	12.5	2840	3470	86	0.80	36.5	21	60
H100L2se	11	15	2840	3470	86	0.80	44.1	25.5	68
1500 RPM – 4 POLES – TYPE SE									
H80sa4se	1.85	2.5	1420	1700	81	0.83	9.2	5.3	23
H80Sb4se	2.2	3	1420	1700	82	0.82	10.5	6.1	24.5
H80L4se	3	4	1435	1700	82	0.82	16	9.1	36
H100S4se	7.5	10	1440	1720	87	0.80	34.6	20	60

Type	kW	Hp	rpm 50Hz	rpm 60Hz	η %	Cos	In* 230V 50Hz	In* 400V 50Hz	Ass.EL. 230V A	Ass.EL. 400V A	Weight kg
3000 RPM – 2 POLES- TYPE SEF with dc security brake											
H71a2sef	1.5	2	2860	3430	80	0.80	6.7	3.9	0,115	0,080	18
H71c2sef	2.2	3	2875	3450	80	0.80	9.6	5.5	0,115	0,080	20
H80Sb2sef	3	4	2890	3470	85	0.84	12.5	7.2	0,150	0,110	25
H80m2sef	4	5.5	2890	3470	85	0.84	16	9.3	0,150	0,110	30
H80L2sef	5.5	7.5	2890	3470	85	0.80	21.6	12.5	0,150	0,110	38
H90S2sef	5.5	7.5	2880	3450	86	0.85	19.1	11	0,170	0,100	42
H90L2sef	7.5	10	2885	3460	86	0.86	26.5	15.3	0,170	0,100	48
H100S2sef	9.2	12.5	2840	3470	86	0.80	36.5	21	-	0,115	62
H100L2sef	11	15	2840	3470	86	0.80	44.1	25.5	-	0,115	70
1500 RPM – 4 POLES – TYPE SEF with dc security brake											
H80sa4sef	1.85	2.5	1420	1700	81	0.83	9.2	5.3	0,150	0,110	25
H80Sb4sef	2.2	3	1420	1700	82	0.82	10.5	6.1	0,150	0,110	26
H80L4sef	3	4	1435	1700	82	0.82	16	9.1	0,150	0,110	38
H100S4sef	7.5	10	1440	1720	87	0.80	34.6	20	-	0,115	62

Dimensions

for motors frame H71 up to frame H100

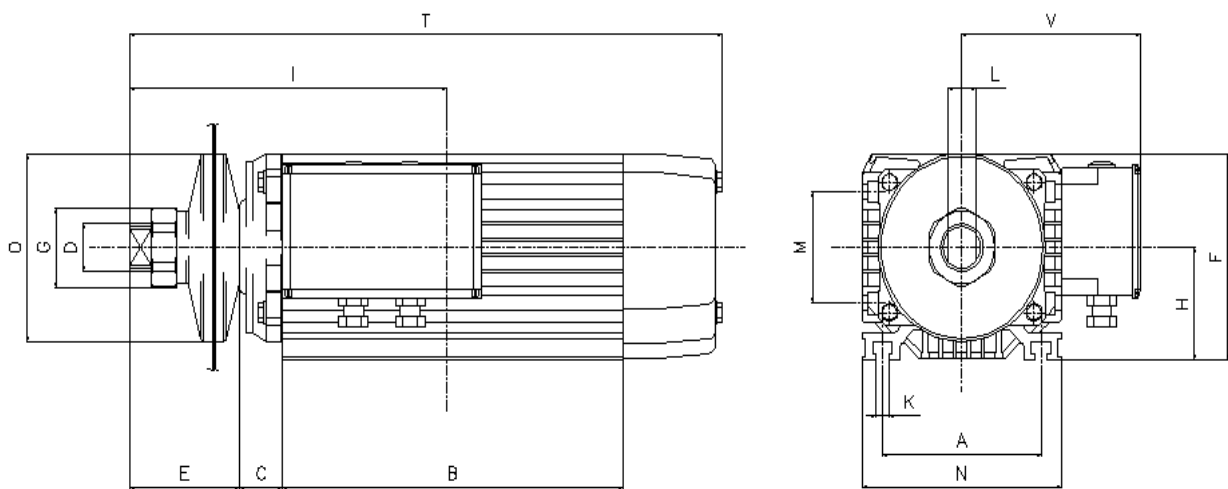

	A	B	C	E	H	K	F	V	I	T	L	D	G	O	M	N
H71	112	240	30	78	71	9	130	126	224	418	20	30	50	118	70	140
H80s	125	240	30	78	80	10.3	149	136	228	422	20	30	50	139	74	160
H80M	125	280	30	78	80	10.3	149	136	248	462	20	30	50	139	74	160
H80L	125	320	30	78	80	10.3	149	136	268	502	20	30	50	139	74	160
H90S	140	330	30	78	90	10.3	165	145	274	535	25	35	60	139	84	177
H90L	140	380	30	78	90	10.3	165	145	299	585	25	35	60	139	84	177
H100S	160	320	42	113	100	14	189	160	315	575	30	50	70	207	84	205
H100L	160	320	42	113	100	14	189	160	315	575	30	50	70	207	84	205

Measures are expressed in millimeters.

Exit shaft dimensions for motors frame H71 up to H100

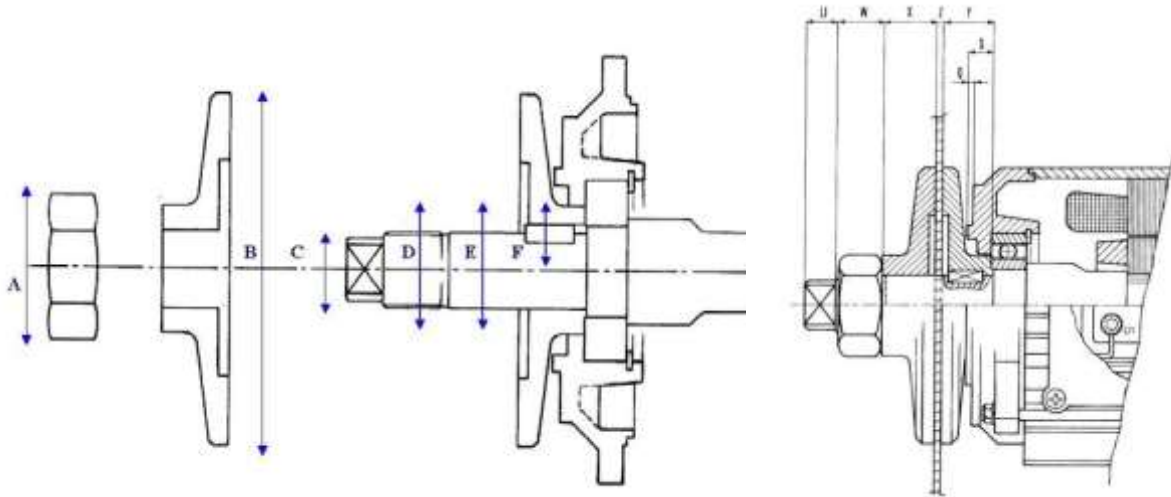

Motor	H71	H80	H90	H100
A	50	50	60	70
B	118	139	139	207
C	20	20	25	30
D	30 x 2	30 x 2	35 x 1.5	45 x 3
E	30	30	35	50
F	8 x 7 x 20	8 x 7 x 20	8 x 7 x 20	8 x 10 x 30
U	15	15	15	15
W	23	23	21	39
X	25	26	26	38
Z	3	3	3	3
Y	25	26	26	38
S	13	13	13	17
Q	3	3	3	3

Dimensions for motors frame H48

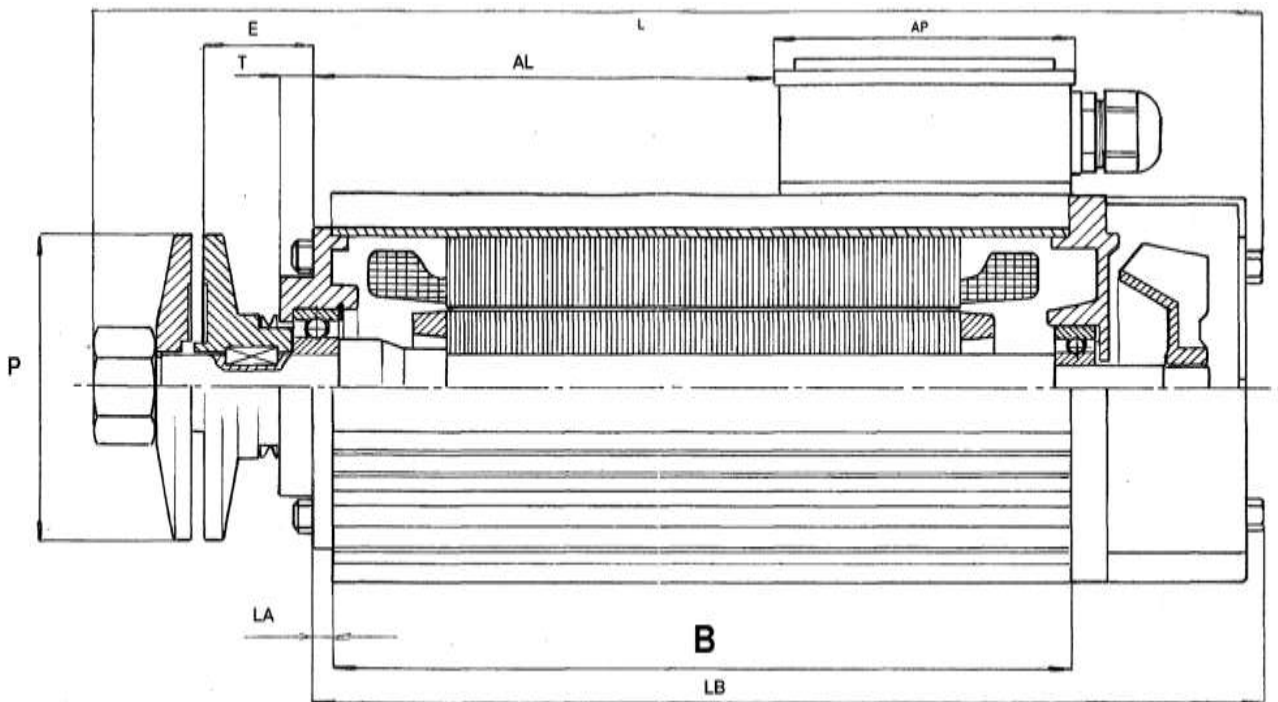

Motor	B	E	L	LA	LB	P	T	AL	AP
H48S	215	32.5	342	5.5	278	90	10	134	88
H48L	255	32.5	382	5.5	318	90	10	174	88

Dimensions of shaft for motors H48

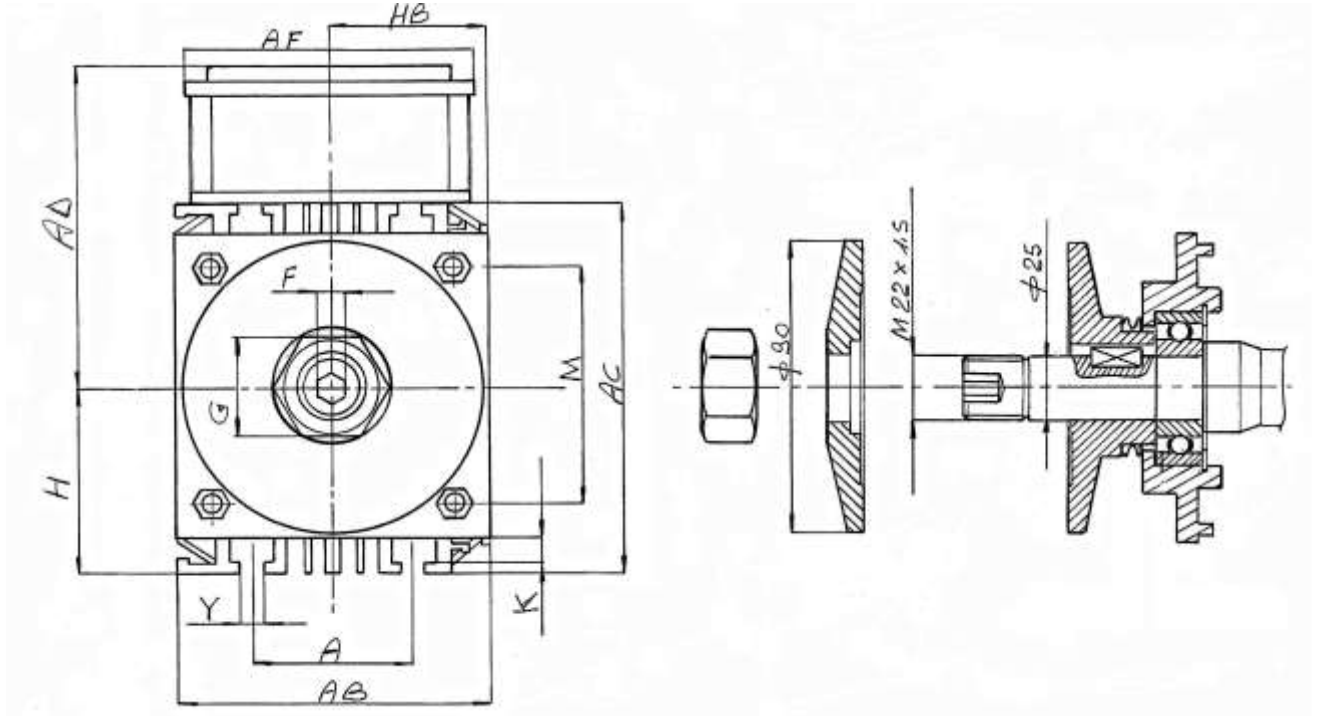

Motor	A	AB	AC	H	HB	AD	AF	F	G	K	Y	M	D*	J**
H48S	48	95	115	57.5	47.5	101	88	8	30	7	8	73.5	22x1.5	25
H48L	48	95	115	57.5	47.5	101	88	8	30	7	8	73.5	22x1.5	25



* Thread measures
 ** Standard shaft diameter

mk elektromotoren AG
Lenzburgerstrasse 30
CH-5600 Ammerswil
Tel. +41 (56) 496 09 10
Fax +41 (56) 496 09 11
info@mk-elektromotoren.ch
www.mk-elektromotoren.ch

